

IZ-100 K

Insertable de Leña Panorámico



CARACTERÍSTICAS TÉCNICAS

Potencia Térmica Máxima 17,9 kW.

Potencia Nominal 14,5 kW.

Temperatura de Humos Media 205 °C.

Rendimiento 81%.

Combustible Leña.

Volumen Calefactable 390 m³.

Consumo 3,98 kg/h.

CO al 13% O₂ 0,10 %.

Partículas al 13% O₂ 30,80 mg/Nm³.

Equipo elaborado en Acero Hasta 5 mm.

Regulación Entrada de Aire Primario

Pintura Anticalórica 800°C. Color Negro.

Tamaño de Tronco 88 cm.

Peso 185 kg.

Medidas (Ancho x Fondo x Alto) 934 x 524 x 563 mm.

Medidas Frontal (Alto x Ancho) 594 x 994 mm.

EQUIPAMIENTO

- Sistema de Doble Combustión y Cristal Limpio.
- Sistema de Triple Combustión.
- Medidas Entrada Leña (AxHxF): 830 x 320 x 365 mm.
- Salida Humos Macho Ø 200 mm en fundición.
- Cristal Serigrafiado 750 °C.
- Puerta y Rejilla de fundición.
- Doble Cámara.
- Opción 4 canalizaciones.
- Válvula Cortatiros.

ACCESORIOS

- Bote de Spray Pintura Anticalórica 800°C. Color Negro.
- Manguito Anticondensaciones. Negro Vitrificado.
- Bastidor con Patas Regulables en Altura.
- Kit con Turbina Tangencial 370 mm, 315 m³/h, 66 W.
- Kit con Turbina Centrifuga 900 m³/h, 275 W.
- 2 Boquillas Ø 80 mm para Canalización Aire Primario.

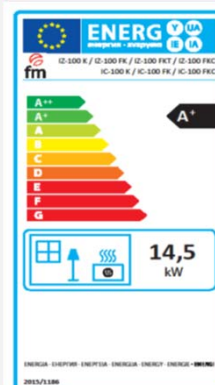

IZ-100 K

Versiones



IZ-100 K

IZ-100 FKT

IZ-100 FKC



IZ-100 K. Interior Vermiculita y Cristal Serigrafiado.

IZ-100 FKT. Interior Fundición y Cristal Serigrafiado. Con T. Tangencial y Bastidor.
IZ-100 FKC. Interior Fundición y Cristal Serigrafiado. Con T. Centrífuga y Bastidor.

Ficha Técnica

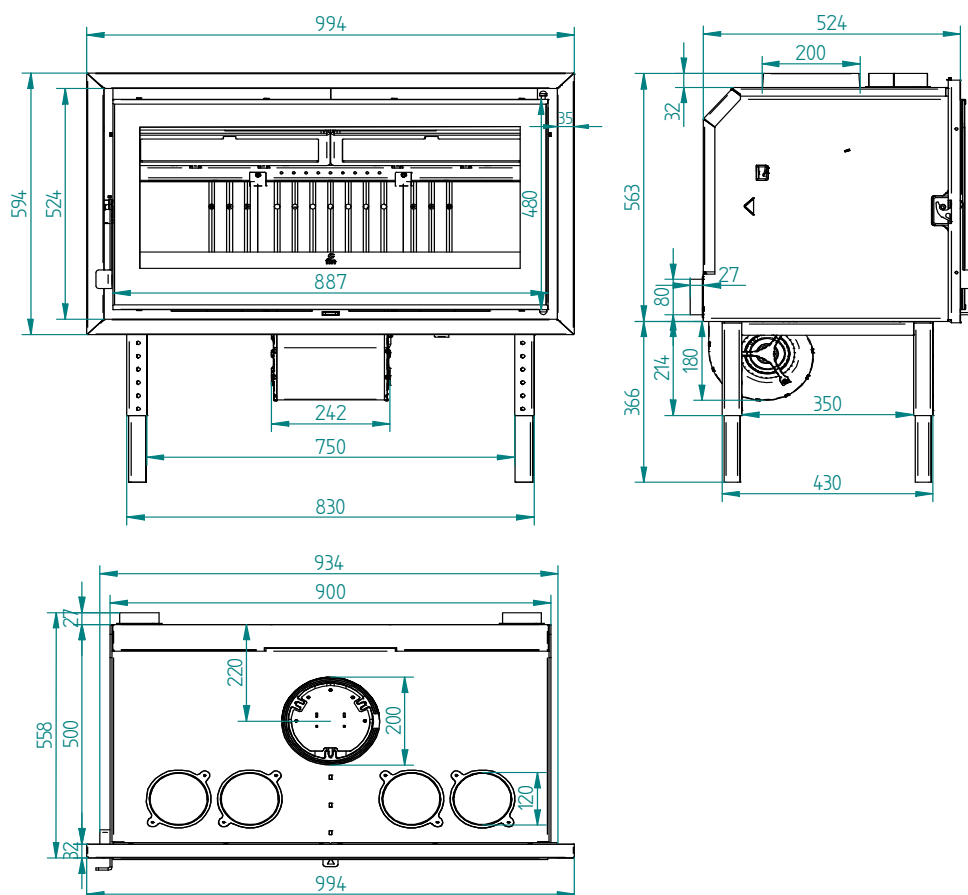

IZ-100 K + KIT TURBINA CENTRÍFUGA 900 m³/h + KIT CANALIZACIÓN AIRE PRIMARIO + BASTIDOR

IZ-100 K

Panoramic Wood Insert



EQUIPMENT

- Double Combustion and Clean Glass System.
- Triple Combustion System.
- Firewood Measures (WxDxH): 830 x 320 x 365 mm.
- Output Male Fumes Ø 200 mm en fundición.
- Silkscreen glass 750 °C.
- Cast iron door and grid.
- Dual Camera.
- Option 4 pipelines.
- Throwshot Shorter Valve.

SPECIFICATIONS

Maximum Thermal Input 17,9 kW.

Rated Power 14,5 kW.

Medium Smoke Temperature 205 °C.

Yield 81%.

Fuel Leña.

Heated Volume 390 m3.

Consumption 3,98 kg/h.

CO 13% O2 0,10 %.

Particulate matter at 13% O2 30,80 mg/Nm3.

Equipment made of Steel Hasta 5 mm.

Primary Air Intake Regulation

Anticaloric Paint 800°C. Color Negro.

Trunk Size 88 cm.

Weight 185 kg.

Measurements (WxDxH) 934 x 524 x 563 mm.

Front Measurements (HxW) 594 x 994 mm.

ACCESSORIES

- Spray Bottle Anticaloric Paint 800°C. Black Color.
- Anti-condensation cuff. Black Vitrified.
- Frame with Height Adjustable Legs.
- Kit with Tangential Turbine 370 mm, 315 m3/h, 66 W.
- Kit with Centrifugal Turbine 900 m3/h, 275 W.
- 2 Nozzles Ø 80 mm for Primary Air Channeling.

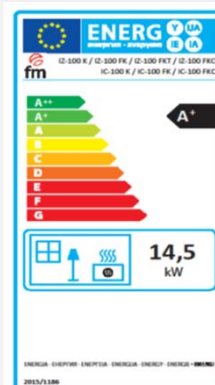

IZ-100 K

Versions



IZ-100 K

IZ-100 FKT

IZ-100 FKC



IZ-100 K. Vermiculite Interior and Silkscreen Glass.

IZ-100 FKT. Interior Cast Iron and Silkscreen glass. With T. Tangential and Frame.

IZ-100 FKC. Interior Cast Iron and Silkscreen glass. With T. Centrifuge and Frame.

Data Sheet

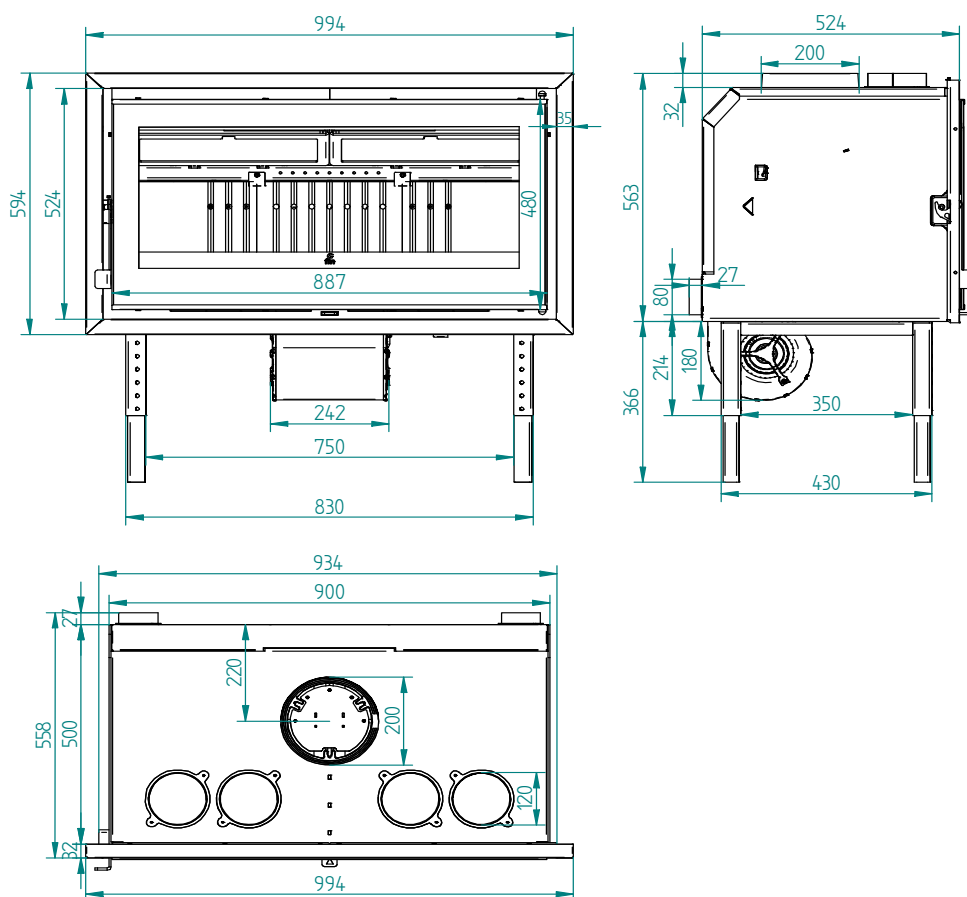

IZ-100 K + KIT TURBINA CENTRÍFUGA 900 m³/h + KIT CANALIZACIÓN AIRE PRIMARIO + BASTIDOR

IZ-100 K

Insert Panoramique à Bois



SPECIFICATIONS

Puissance Thermique Maximale 17,9 kW.

Puissance Nominale 14,5 kW.

Température Moyenne de Fumée 205 °C.

Rendement 81%.

Combustible Leña.

Volume Chauffé 390 m³.

Consommation 3,98 kg/h.

CO 13% O2 0,10 %.

Matières particulaires 13 % O2 30,80 mg/Nm³.

Équipement en Acier Hasta 5 mm.

Règlement sur l'admission d'air primaire

Peinture Anticalorique 800°C. Color Negro.

Taille du tronc 88 cm.

Poids 185 kg.

Mesures (L x P x H) 934 x 524 x 563 mm.

Mesures avant (H x L) 594 x 994 mm.

ÉQUIPEMENT

- Double combustion et système de verre propre.
- Système de combustion triple.
- Mesures d'intrants bois (AxHxF): 830 x 320 x 365 mm.
- Sortie de fumées mâle Ø 200 mm en fundición.
- Verre sérigraphié 750 °C.
- Porte et grille en fonte.
- Double caméra.
- Pipelines de l'option 4.
- Valve Throwshot plus courte.

ACCESSOIRES

- Peinture chaude en aérosol 800°C. Couleur Noir.
- Brassard anti-condensation. Noir vitrifié.
- Cadre avec pieds réglables en hauteur.
- Kit avec turbine tangentielle 370 mm, 315 m³/h, 66 W.
- Kit avec turbine centrifuge 900 m³/h, 275 W.
- 2 buses Ø 80 mm pour la canalisation d'air primaire.

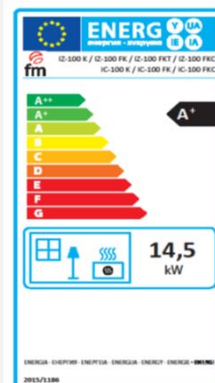

IZ-100 K

Versions



IZ-100 K

IZ-100 FKT

IZ-100 FKC



IZ-100 K. Vermiculite intérieure et Verre Sérigraphié.

IZ-100 FKT. Vermiculite intérieure et Verre Sérigraphié. Avec T. Tangential et Frame.
IZ-100 FKC. Vermiculite intérieure et Verre Sérigraphié. Avec centrifugeuse et Frame.

Fiche Technique

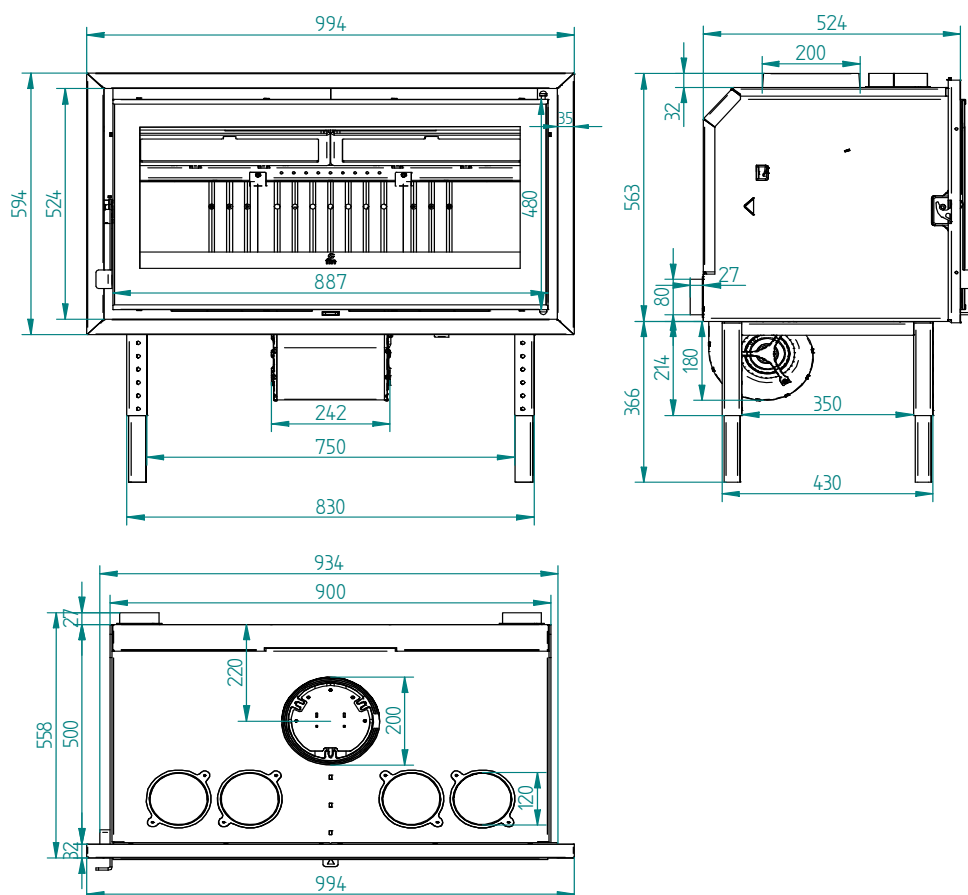

IZ-100 K + KIT TURBINA CENTRÍFUGA 900 m³/h + KIT CANALIZACIÓN AIRE PRIMARIO + BASTIDOR

IZ-100 K

Lenha Inserível Panorâmico



ESPECIFICAÇÕES

Potência Térmica Máxima 17,9 kW.

Potência Nominal 14,5 kW.

Temperatura Média de Fumo 205 °C.

Rendimento 81%.

Combustível Lenha.

Volume Aquecido 390 m³.

Consumo 3,98 kg/h.

CO 13% O₂ 0,10 %.

Partículas em Suspensão 13% O₂ 30,80 mg/Nm³.

Equipamento em Aço Hasta 5 mm.

Regulação da Admissão de Ar Primário

Tinta Anticalórica 800°C. Color Negro.

Tamanho do Tronco 88 cm.

Peso 185 kg.

Medições (LxPxA) 934 x 524 x 563 mm.

Medições Frontais (AxL) 594 x 994 mm.

EQUIPAMENTOS

- Combustão dupla e sistema de vidro limpo.
- Sistema de Combustão Tripla.
- Medidas entrada lenha (LxPxA): 830 x 320 x 365 mm.
- Saída fumos machos Ø 200 mm en fundición.
- Vidro serigrafado a 750 °C.
- Porta e grade de fundição.
- Câmara dupla.
- Opção 4 pipelines.
- Throwshot Válvula mais curta.

ACESSORIOS

- Frasco de Spray Tinta Anticalórica 800°C. Cor Preto.
- Punho anti-condensação. Preto Vitroficado.
- Quadro com pernas ajustáveis em altura.
- Kit com Turbina Tangencial 370 mm, 315 m³/h, 66 W.
- Kit com Turbina Centrífuga 900 m³/h, 275 W.
- 2 bicos Ø 80 mm para canalização de ar primária.

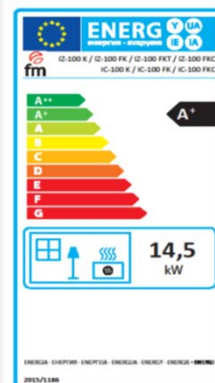

IZ-100 K

Versões



IZ-100 K

IZ-100 FKT

IZ-100 FKC



IZ-100 K. Interior Vermiculita e Vidro Serigrafado.

IZ-100 FKT. Interior Vermiculita e Vidro Serigrafado. Com T. Tangencial e Armação

IZ-100 FKC. Interior Vermiculita e Vidro Serigrafado. Com T. Ccentrífuga e Armação.

Ficha Técnica

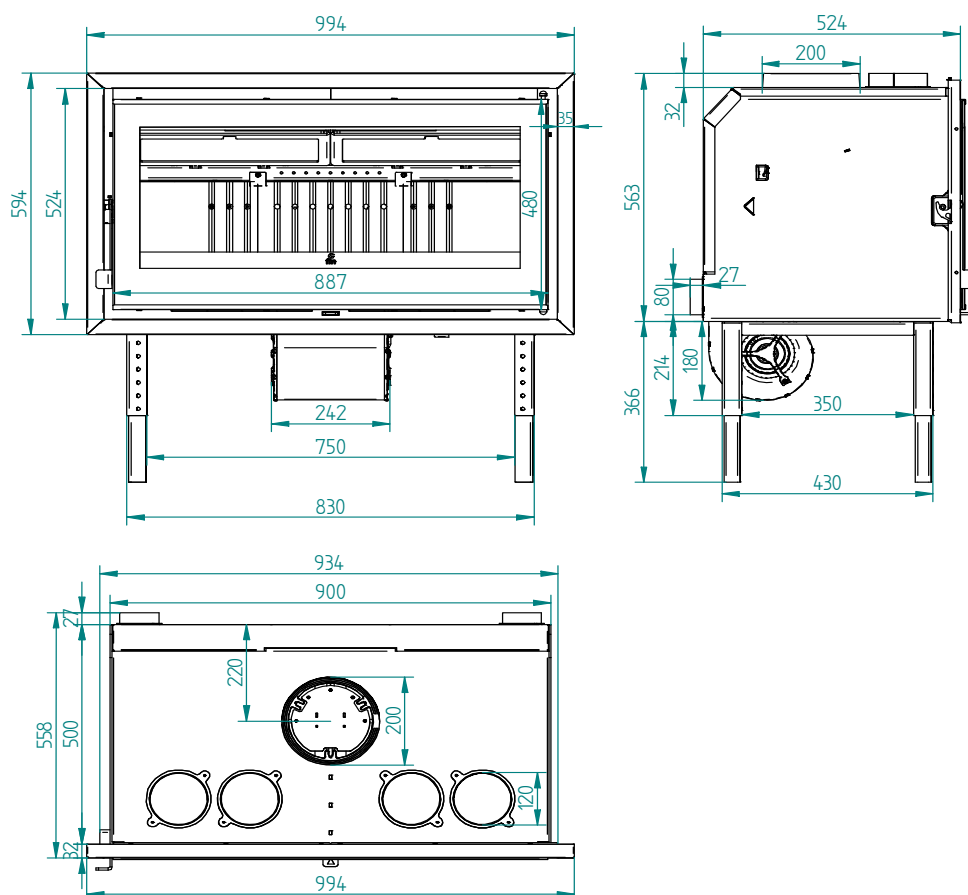

IZ-100 K + KIT TURBINA CENTRÍFUGA 900 m3/h + KIT CANALIZACIÓN AIRE PRIMARIO + BASTIDOR